



FIXED PANEL SCREEN FITTING INSTRUCTIONS – FX

Components:

- 1 x Bag 1 - Allen Keys (1.5, 2.5,3,4)
- 1x Bag 11 - Packers
- 1 x Clear Silicon
- 1 x Blue Masking Tape
- 1 x Screen Fitting Instructions

Other equipment required:

- No 1 Square Drive Screwdriver
- Caulking Gun
- Drill
- Level
- Pencil

Checked by: _____

Date: _____

Included in with this shower package:

- | | | | |
|---|--------------------------|------------------------|--------------------------|
| 1 x Fixed Panel 21 B | <input type="checkbox"/> | 1 x Clear Silicon Tube | <input type="checkbox"/> |
| 1 x Wall Channel Tube | <input type="checkbox"/> | | |
| 1 x 4mm Drill Bit | <input type="checkbox"/> | | |
| 1 x Bag18 – 8x6Gx40 Sq drive screws & wall plugs – 1x4mm drill bit | <input type="checkbox"/> | | |

PLEASE NOTE: Stand glass upright at all times. Keep glass panels level with the floor to avoid damaging corners.

NO RESPONSIBILITY WILL BE TAKEN BY ATLANTIS FOR ANY GLASS BREAKAGES OR CHIPPED EDGES.

GLASS RECEIVER CHANNEL MUST BE INSTALLED ONTO THE WATERPROOFING BEFORE THE WALLS ARE TILED

INSTRUCTIONS FOR FX-NTRB CONFIGURATION



1. Installer – When Architectural Finish is fitted to base. Trim the internal leg off the wall channel to adequately clear the base surface. Ensure the wall channel interlocks correctly with the base.

2. Position the glass receiver channel over the base glazing channel. Use a straight edge and mark the wall to indicate where the wall channel is plumb.

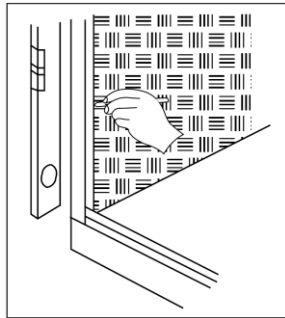

3. Apply a silicon seal to full length of channel.

Silicon used must be compatible with anodised aluminium as well as the waterproofing being used

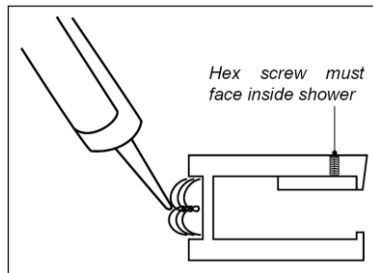

4. Ensure the glass receiver channel is located firmly over the base glazing channel. The machine recess in the wall glazing channel must firmly locate over the base glazing channel.

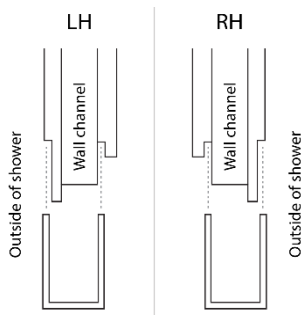

5. Locate the framing timber. Use the 4mm drill bit to drill holes through the glass receiver channel. Fix four screws through the channel in the wall framing (use wall plugs if required – **BAG 18**).

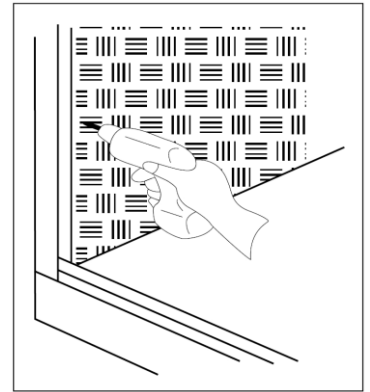

6. Apply a continuous bead of silicon to the full length of the channel and waterproofing, indicated by the dark line (inside channel).

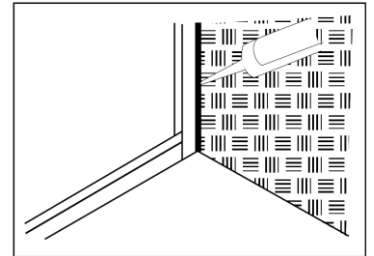

7. Slide the sill infill into position and apply plastic packers into the base glazing channel in locations as shown.

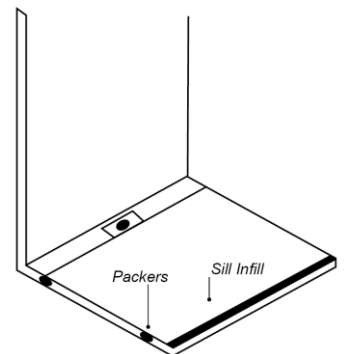

8. CRITICAL SEAL



Remove the dust and dirt first. Seal the connection between the glass receiver channel and the base glazing channel with clear silicon, prior to the installation of panel **21 B**. Ensure the corner junction between wall channel and base channel is full of silicon before final glass placement. It is vital that all junctions are sealed sufficiently.

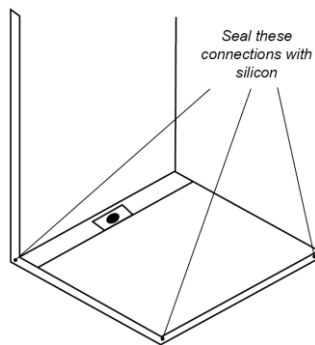
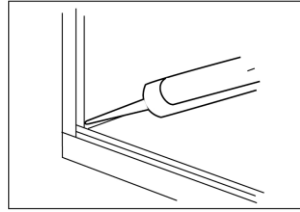

Prior to installation of fixed panel and infill all connections of channels must be sealed with clear silicon supplied.

9. Locate the glass panel **21 B** into the glazing channels. The top of the panels should align to the top of the glass receiver channel.

Add or remove plastic packers in the base glazing channel as necessary.

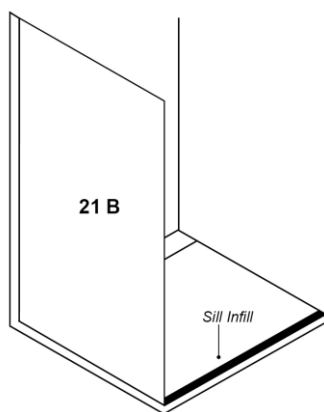

10. SILL INFILL

Apply a continuous bead of clear silicon to each inside face of the base channel. Ensure the ends of the infill are sealed and place into the base channel in the location as shown. Infill may be trimmed if required.

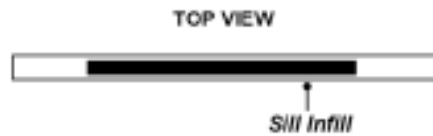

11. FASTENING GLASS

Secure the glass panel into the receiver channels by tightening hex screws firmly with hex key supplied. **Do not overtighten.**

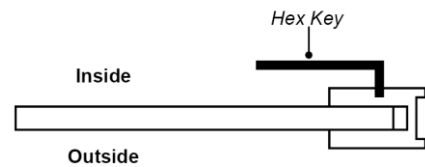

12. SILICON APPLICATION

Using the blue tape supplied, mask the glazing channel and glass at the intersections shown.

Apply clear silicon to the inside and outside of the glass panel (TWO SIDES OF GLASS).

Remove the excess silicon. Remove the masking tape immediately after application.

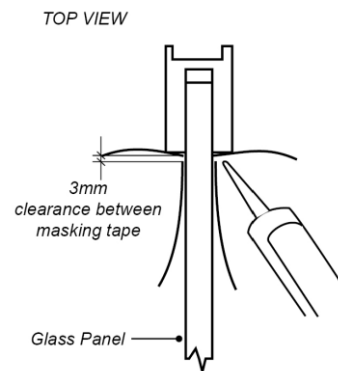

INSTRUCTIONS FOR FX-TRB CONFIGURATION



Installer – When Architectural Finish is fitted to base. Trim the internal leg off the wall channel to adequately clear the base surface. Ensure the wall channel interlocks correctly with the base.

1. Position the glass receiver channel over the base glazing channel.

Use a straight edge and mark the wall to indicate where the wall channel is plumb.

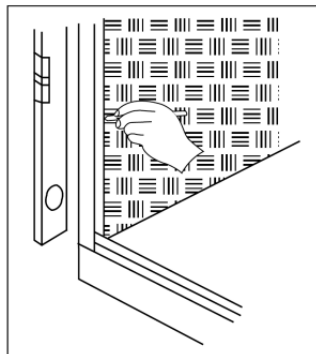

2. Apply a silicon seal to full length of channel. Silicon used must be compatible with anodised aluminium as well as the waterproofing being used.

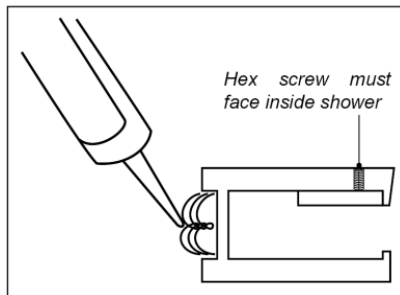

3. Ensure the glass receiver channel is located firmly over the base glazing channel. The machine recess in the wall glazing channel must firmly locate over the base glazing channel.

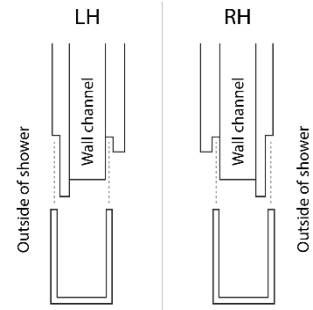

4. Locate the framing timber. Use the 4mm drill bit to drill holes through the glass receiver channel. Fix four screws through the channel in the wall framing (use wall plugs if required-**BAG 18**).

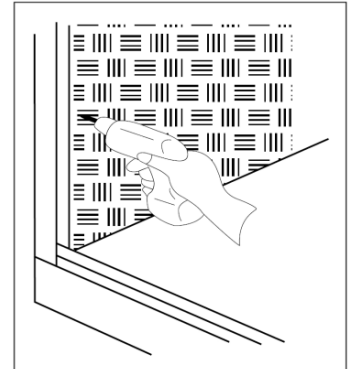

5. Apply a continuous bead of silicon to the full length of the channel and waterproofing, indicated by the dark line (inside channel).

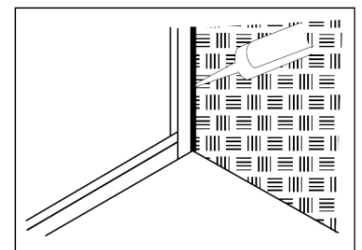

6. PREPARATION FOR GLASS INSTALLATION

Slide the sill infill into position and apply plastic packers into the base glazing channel in locations as shown.

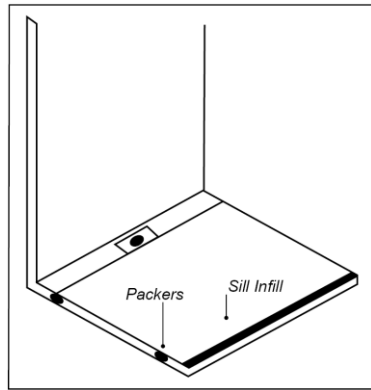

7. CRITICAL SEAL

Remove the dust and dirt first. Seal the connection between the glass receiver channel and the base glazing channel with clear silicon, prior to the installation of panel **21**

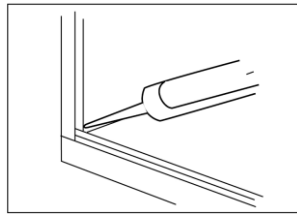

B. Ensure the corner junction between wall channel and base channel is full of silicon before final glass placement. It is vital that all junctions are sealed sufficiently.

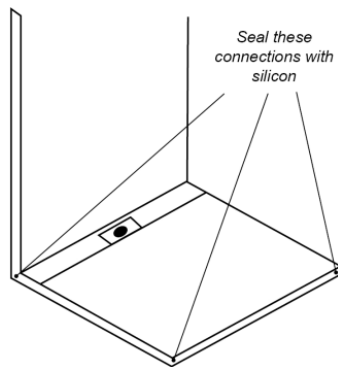

Prior to installation of fixed panel and infill all connections of channels must be sealed with clear silicon supplied.

8. INSTALLATION OF FIXED PANEL

Locate the glass panel **21 B** into the glazing channels. The top of the panels should align to the top of the glass receiver channel. Add or remove plastic packers in the base glazing as necessary.

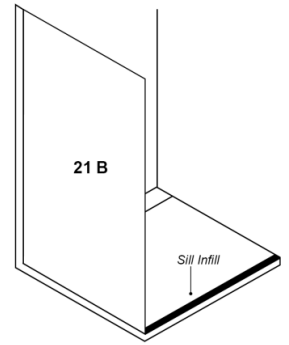

9. SILL INFILL

Apply a continuous bead of silicon to each inside face of the base channel. Ensure the ends of the infill are sealed and place into the base channel in the location as shown. Infill can be trimmed if required

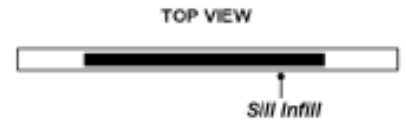

10. SILICON APPLICATION

Using the blue tape supplied, mask the glazing channel and glass at the intersections shown.

Apply clear silicon to the inside and outside of the glass panel (TWO SIDES OF GLASS). Remove the excess silicon. Remove the masking tape immediately after application.

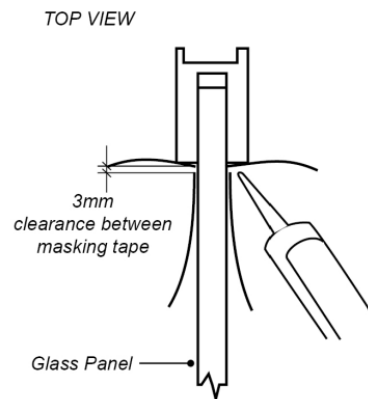

11. TOP BRACE INSTALLATION

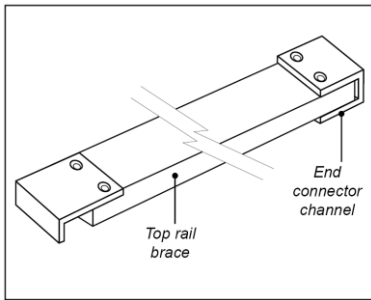

Choose the preferred distance of the top rail from the tiled wall, as shown in Fig 1.

13. Apply an 8mm dot of clear silicon inside the end of the top rail brace in location as shown.

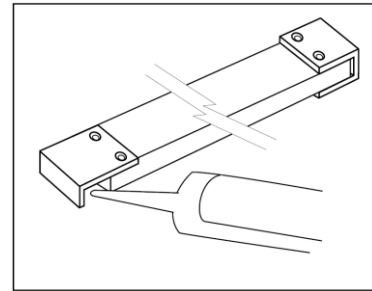
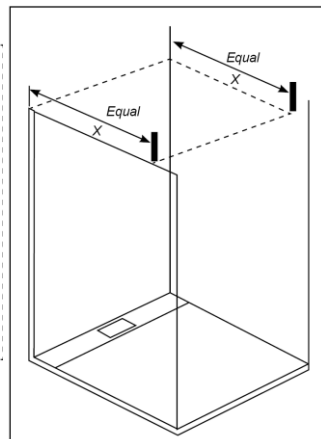
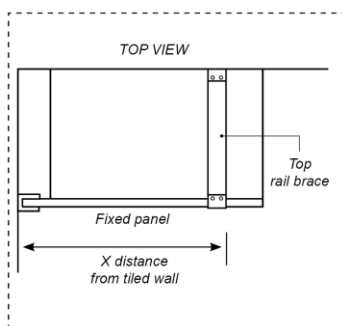
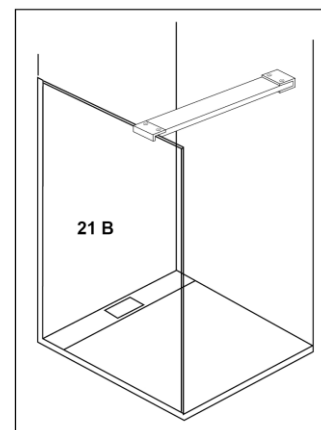

Fig. 1



14. Trim the top rail brace to length if necessary. Drill and retain with screws supplied. Slide into the end connector channels. Drill into CSK holes provided. Fix with the short CSK screws.



12. Mount the end connector channel the end connector channel. Ensure the top face of it is 6mm above the top of the fixed glass panel. CSK holes face upward.

