

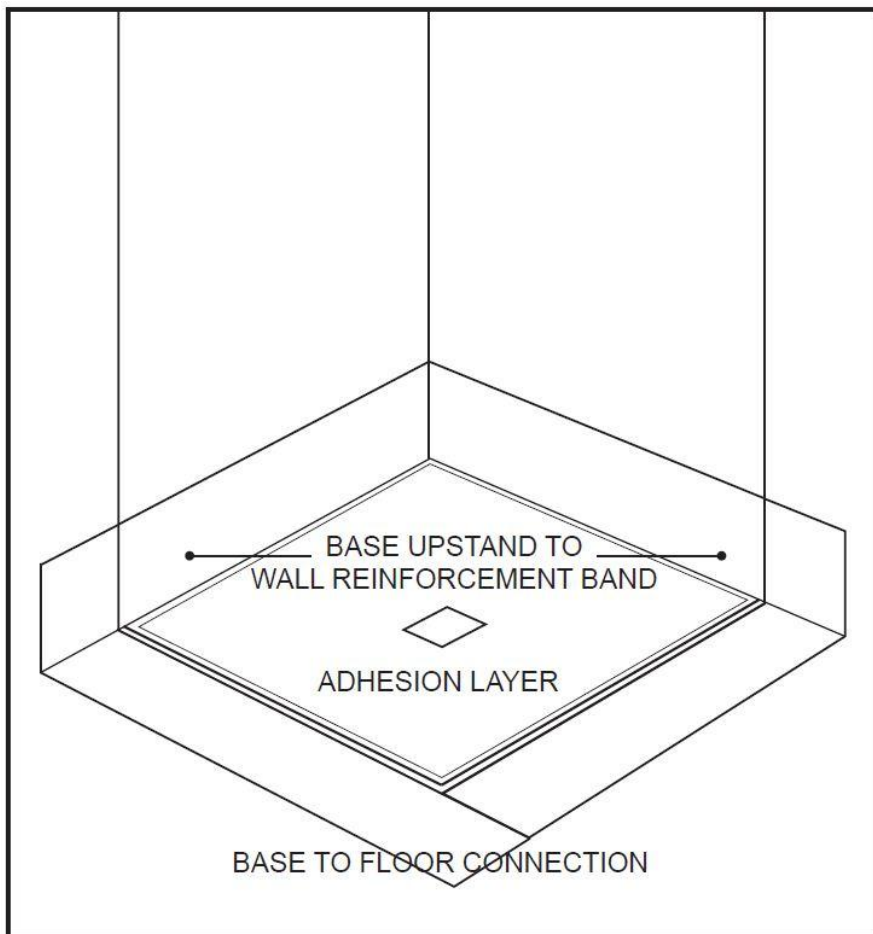

Essential Connection Kit Instructions

Two Wall



1 BLUE PRIMING

SHOWER BASE / PLASTER BOARD / FIBRE CEMENT SHEET / TILE AND SLATE UNDERLAY PRIMER

INSTRUCTIONS:

Directions: Clean the surface to be primed so that all dust or other contaminants that may adversely affect the adhesion of the reinforcement bands and adhesion layer are removed. Shake well before use. Pour the blue primer into a suitable container, do not dilute contents.

Prior to applying primer ensure reinforcement bands and adhesion layer are correctly cut to fit.

Application: Apply primer to all of surfaces as shown in the detail below including the shower base, extending 80mm onto the floor fibre cement sheet / tile and slate underlay and up the walls 150mm using a roller or brush (see Fig. 1).

Drying Time: Drying will occur in approximately 15 minutes dependant on air temperature. When fully cured, the primer will feel tacky to the touch, but will not come off the surface. Allow primer to fully cure before covering with the Reinforcement Bands.

Clean Up: Wash brush/roller and container with soap and warm water.

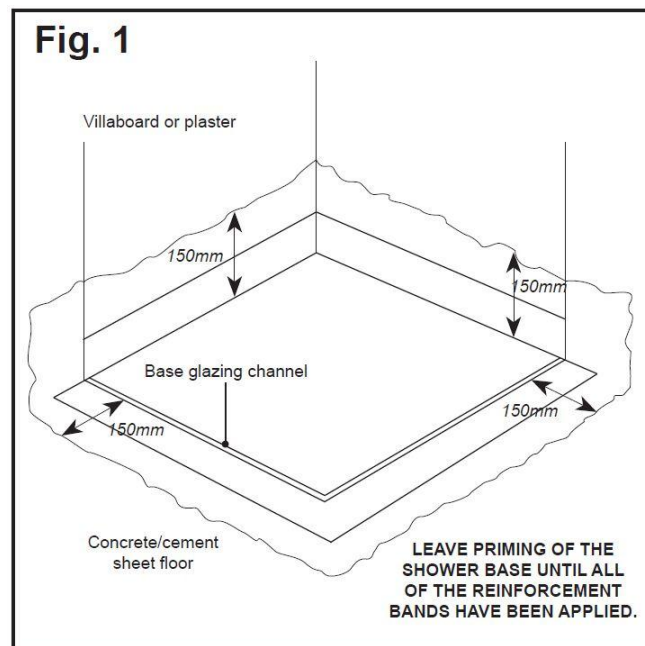

2 APPLICATION OF SELF ADHESIVE REINFORCEMENT BANDS

Apply reinforcement bands firmly to all applicable surfaces. A small roller may be used for this. Gradually peel back the release paper as the reinforcement bands are applied.

Do not remove all the release paper at once.

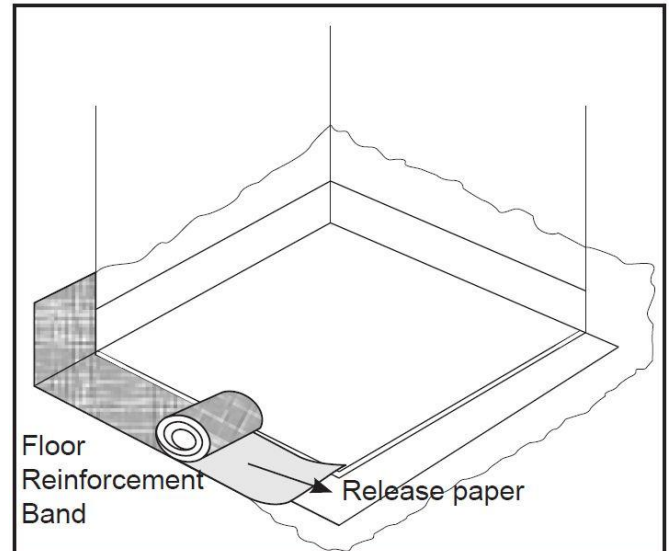

3 FIRST BASE TO FLOOR REINFORCEMENT BAND

Apply 150mm wide Floor Reinforcement Bands to the base and the floor.

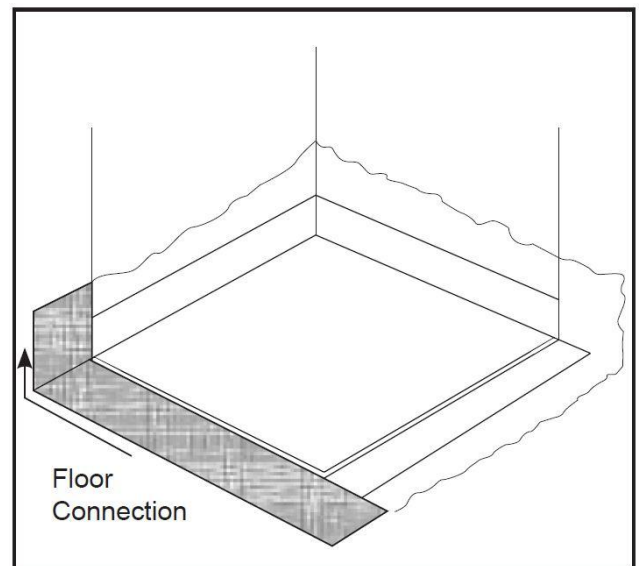

4 SECOND BASE TO FLOOR REINFORCEMENT BAND

Apply primer to the surface being overlapped by the second reinforcement band.

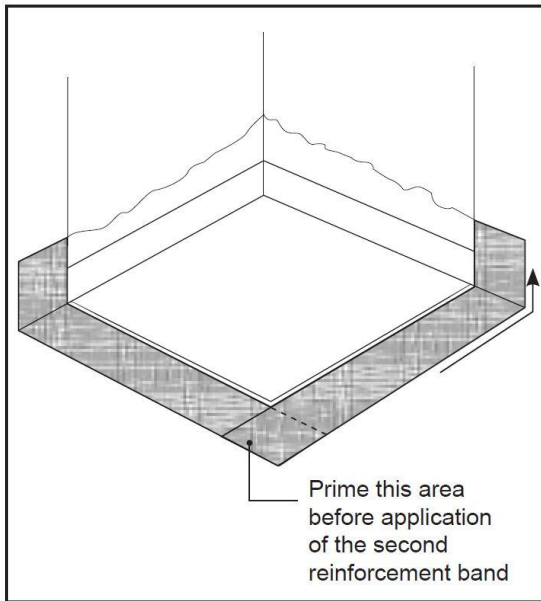

5 BASE UPSTAND TO WALL REINFORCEMENT BAND

Apply primer to the surfaces being overlapped by the wall reinforcement band.

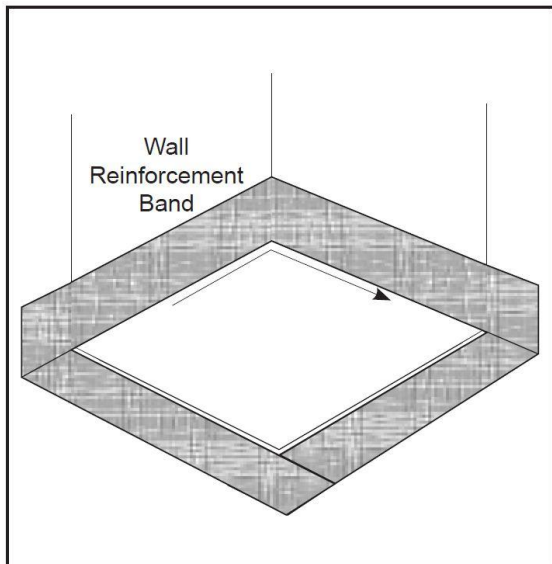

6 ADHESION LAYER

NOTE: The shower base has a waterproof surface. The function of the Adhesion Layer (supplied) is to provide an adhesion surface only. Using this method allows for a large range of liquid waterproofing products to be used for waterproofing over the entire shower area.

APPLICATION STEPS

- 1 The shower base must be clean, dry and free of any foreign matter.
- 2 Cut the Adhesion Layer (supplied) to size to fit over the surface of the base. As the layer is for adhesion only, approximate measurements are acceptable and it is not necessary to cover the base exactly.

3 PRIME THE SHOWER FLOOR.

- 4 Remove the adhesion layer release paper gradually while pressing the adhesion layer firmly to the base.

We recommend using a small roller to ensure the adhesion layer is bonded 100% to the shower base.

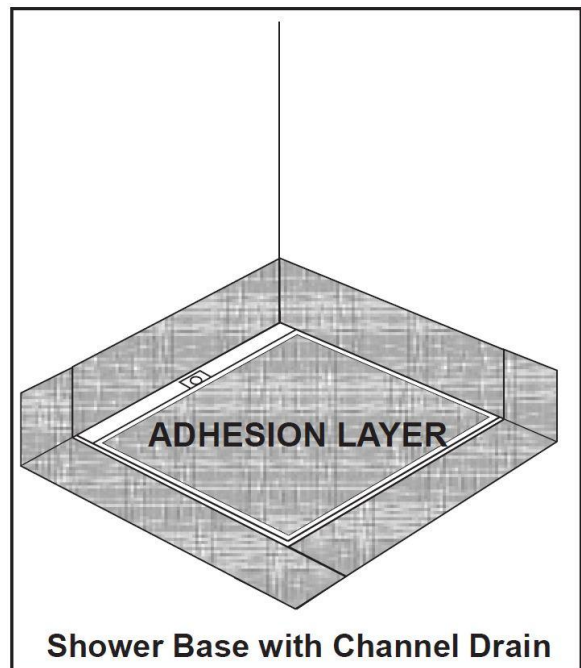

Recommended Compatible Liquid Waterproofing

- for use with Atlantis Essential Connections

Once the Atlantis Reinforcement Bands/Essential Connections have been applied to the wall and Atlantis Shower Base, the following liquid waterproofing products can be used with this system:

CHEVALINE DEXX (Equus)

DAMPFIX 3, DAMPFIX PU, DAMPFIX GOLD Wet Area Membrane (ASA Bostik)

DAVCO K10 PLUS Wet Area Membrane (Davco)

DUROSET and DUROQUIK Wet Area Membrane (Waterproofing Systems)

FLEXI-SEAL Interior Waterproofing Systems (Flexco)

GRIPSET 38 Liquid Rubber Membrane (Gripset Industries)

LATICRETE 9235 9237 9240 Liquid Applied Waterproofing Membranes (Laticrete)

LIQUID FLASH 2 Waterproofing Membrane (Construction Chemicals)

MAPEGUM WPS and MAPELASTIC Wet Area Membranes (Mapei)

RASOLASTIK and RASOGUM Wet Area Membranes (Protective Surfaces)

SUPERFLEX Wet Area Membrane (Ardex)

ULTRASEAL Wet Area Membrane (ASA Bostik)

WPM001 / WPM300 Waterproofing Membranes (Ardex)

WARRANTY

Atlantis Bathroom Style Pty Ltd warrants that the adhesion of these products to the Reinforcement Bands, subject to correct application by a properly qualified tradesperson.

It's possible to adhere tiles directly to the fibreglass shower base. An adhesive that is compatible with fibreglass must be used. Atlantis recommends Mapei Keralastic T or SikaCeram 255 Starflex.

Please make sure you follow the manufacturers instruction.

Its recommended an Epoxy grout be used between tiles



Essential Connection Kit Instructions

Three Wall

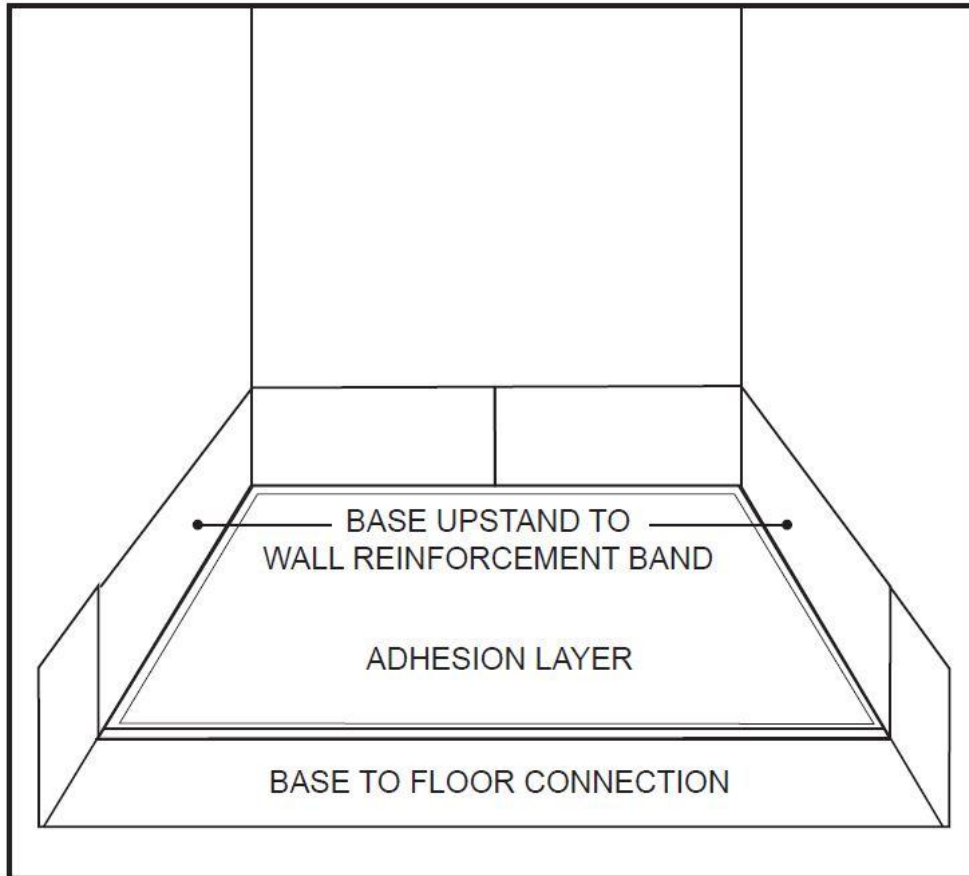

1 BLUE PRIMING

SHOWER BASE / PLASTER BOARD / FIBRE CEMENT SHEET / TILE AND SLATE UNDERLAY PRIMER

INSTRUCTIONS:

Directions: Clean the surface to be primed so that all dust or other contaminants that may adversely affect the adhesion of the reinforcement bands and adhesion layer are removed. Shake well before use. Pour the blue primer into a suitable container, donot dilute contents.

Prior to applying primer ensure reinforcement bands and adhesion layer are correctly cut to fit.

Application: Apply primer to all of surfaces as shown in the detail below including the shower base, extending 80mm onto the floor fibre cement sheet / tile and slate underlay and up the walls 150mm using a roller or brush (see Fig.1).

Drying Time: Drying will occur in approximately 15 minutes dependant on air temperature. When fully cured, the primer will feel tacky to the touch, but will not come off the surface. Allow primer to fully cure before covering with the Reinforcement Bands.

Clean Up: Wash brush/roller and container with soap and warm water.

2 APPLICATION OF SELF ADHESIVE REINFORCEMENT BANDS

Apply reinforcement bands firmly to all applicable surfaces. A small roller may be used for this. Gradually peel back the release paper as the reinforcement bands are applied.

Do not remove all the release paper at once.

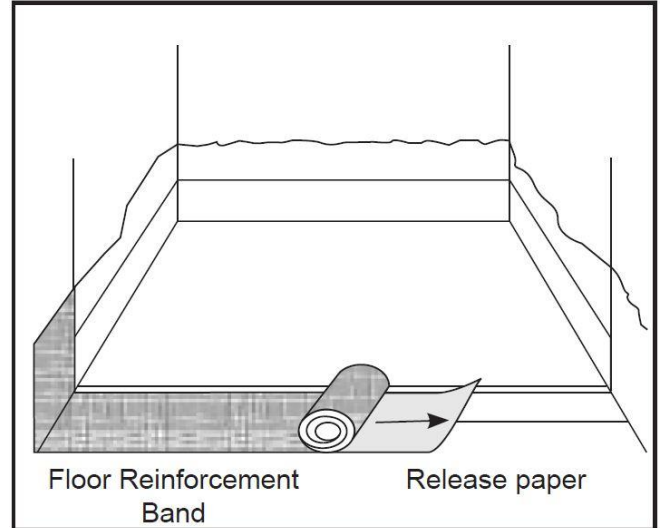

3 BASE TO FLOOR REINFORCEMENT BAND

Apply 150mm wide Floor Reinforcement Band to the base and the floor.

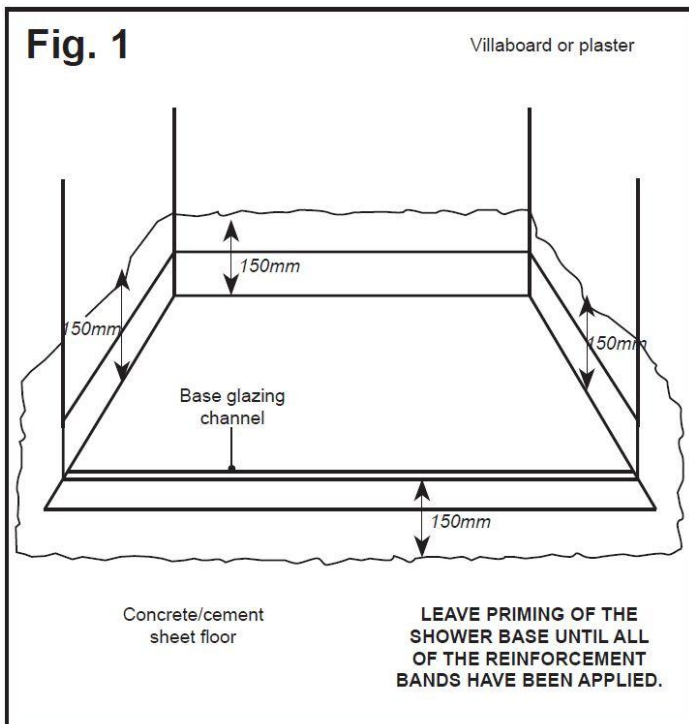
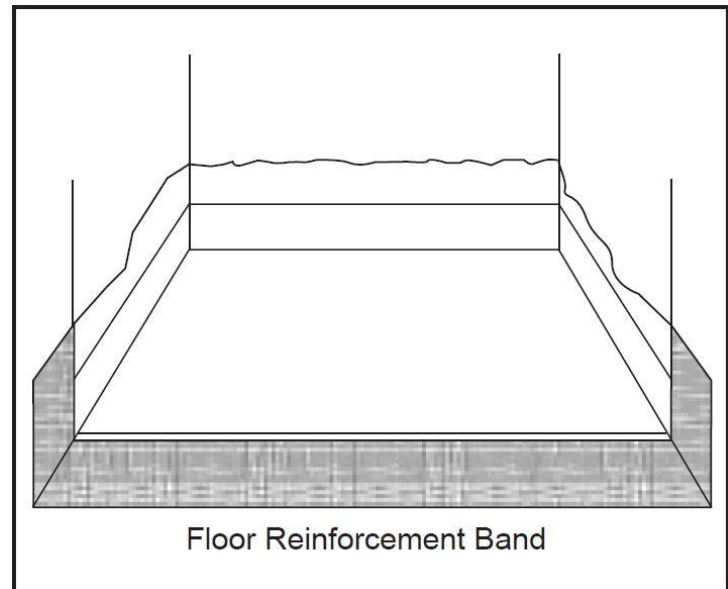

4 BASE UPSTAND TO WALL REINFORCEMENT BAND

Apply primer to the surfaces being overlapped by the wall reinforcement bands.

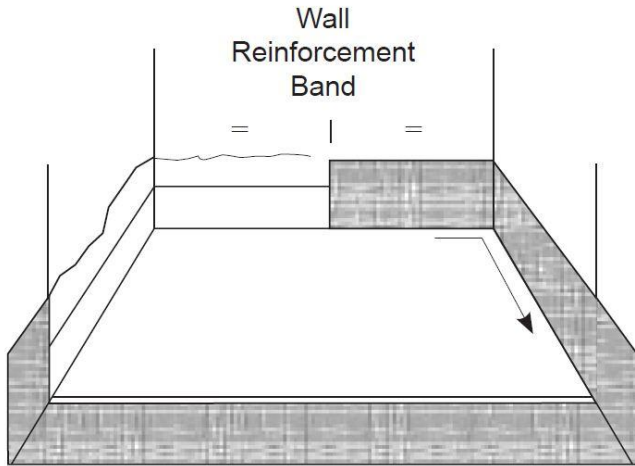

5 ADHESION LAYER

NOTE: The shower base has a waterproof surface. The function of the Adhesion Layer (supplied) is to provide an adhesion surface only. Using this method allows for a large range of liquid waterproofing products to be used for waterproofing over the entire shower area.

APPLICATION STEPS

- 1 The shower base must be clean dry and free of any foreign matter.
- 2 Cut the Adhesion Layer (supplied) to size to fit over the surface of the base. As the layer is for adhesion only, approximate measurements are acceptable and it is not necessary to cover the base exactly.
- 3 **PRIME THE SHOWER FLOOR.**
- 4 Remove the adhesion layer release paper gradually while pressing the adhesion layer firmly to the base.

We recommend using a small roller to ensure the adhesion layer is bonded 100% to the shower base.

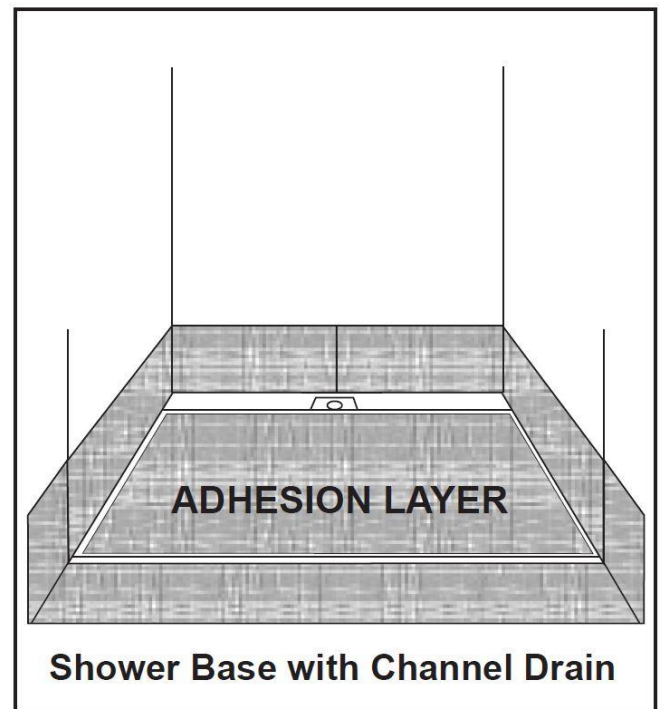
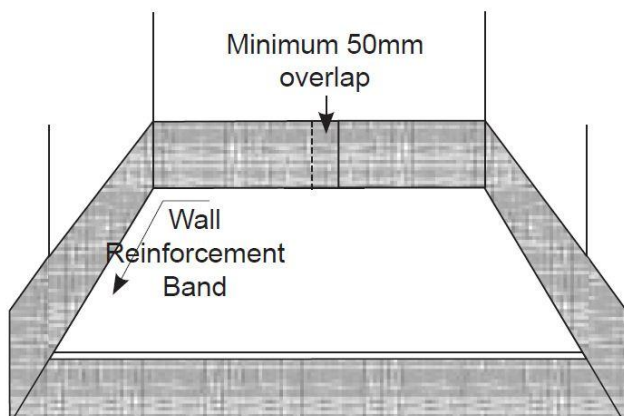

Recommended Compatible Liquid Waterproofing

- for use with Atlantis Essential Connections

Once the Atlantis Reinforcement Bands/Essential Connections have been applied to the wall and Atlantis Shower Base, the following liquid waterproofing products can be used with this system:

CHEVALINE DEXX (Equus)

DAMPFIX 3, DAMPFIX PU, DAMPFIX GOLD Wet Area Membrane (ASA Bostik)

DAVCO K10 PLUS Wet Area Membrane (Davco)

DUROSET and DUROQUIK Wet Area Membrane (Waterproofing Systems)

FLEXI-SEAL Interior Waterproofing Systems (Flexco)

GRIPSET 38 Liquid Rubber Membrane (Gripset Industries)

LATICRETE 9235 9237 9240 Liquid Applied Waterproofing Membranes (Laticrete)

LIQUID FLASH 2 Waterproofing Membrane (Construction Chemicals)

MAPEGUM WPS and MAPELASTIC Wet Area Membranes (Mapei)

RASOLASTIK and RASOGUM Wet Area Membranes (Protective Surfaces)

SUPERFLEX Wet Area Membrane (Ardex)

ULTRASEAL Wet Area Membrane (ASA Bostik)

WPM001 / WPM300 Waterproofing Membranes (Ardex)

WARRANTY

Atlantis Bathroom Style Pty Ltd warrants that the adhesion of these products to the Reinforcement Bands, subject to correct application by a properly qualified tradesperson.

It's possible to adhere tiles directly to the fibreglass shower base. An adhesive that is compatible with fibreglass must be used. Atlantis recommends Mapei Keralastic T or SikaCeram 255 Starflex.

Please make sure you follow the manufacturers instruction.

Its recommended an Epoxy grout be used between tiles